

HANGING RECOMMENDATIONS

IMPORTANT – Please read the following hanging recommendations carefully before proceeding.

If you have any queries, please contact Tektura’s technical department on 020 7536 3300

We recommend that Decoupage is applied to a clean, smooth wall surface which has been primed with Tektura’s Tekfix Primer. For previously decorated surfaces, please refer to the attached IMPORTANT TECHNICAL INFORMATION sheet for specific recommendations.

Decoupage wallcovering is hand painted, and therefore some variations may occur between batches. Whilst every care is taken to ensure colour continuity, differences in texture are natural and intentional.

Tektura only recommends the use of Tekfix/Tekfix 65 adhesive for the installation of any Decoupage wallcoverings.

VERTICAL INSTALLATION

Using a brush, apply a generous amount of Tekfix/Tekfix 65 adhesive to the back of the Decoupage wallcovering, ensuring edges are adequately pasted.

Allow 3-5 minutes for the adhesive to soak into the paper backing before applying to the wall surface.

Smooth wallcovering with a damp sponge from the centre outwards on to the substrate in order to achieve an even finish.

Apply subsequent lengths in strict sequence (do not reverse). Joins can be overlapped and cut or back-torn and overlapped by approximately 2mm. **(see Tearing to Shape section for separate details).**

Adhesive maybe re-applied to unsecured edges should this be necessary.

Once 3 lengths are installed, inspect and contact Tektura on 020 7536 3300 if you have any queries

This type of vertical installation should be ‘set out’ on the intended area of decoration.



TILE INSTALLATION

Prior to installation, measure the centre of the wall in order to establish a centre point and calculate the total number of tiles required for the complete area **(see diagram 1).**

Apply a generous amount of Tekfix/Tekfix 65 adhesive to the first 4 tiles paying particular attention to the edges; allow adhesive to soak in for 3-5 minutes.

Starting at the centre point, apply the first row of tiles as shown **(see diagram 2)** ensuring the row remains square by using a spirit level and plumb line.

For best results alternate direction of tiles as shown, the back of each tile is printed with a directional arrow **(see diagram 3).**

Smooth tiles with a damp sponge from the centre outwards to achieve an even finish.

Tiles should be butt joined but can be overlapped by approximately 2mm if necessary.

Once 1 row or 5 tiles, (whichever is the smaller quantity), is installed, inspect and contact Tektura on 020 7536 3300 if you have any queries

Each wall area should be ‘set out’ independently, although you will need to ensure that each row corresponds with the tiles on any adjacent walls.

Please note that tiles may be subject to slight horizontal expansion, this is a recognised product characteristic.

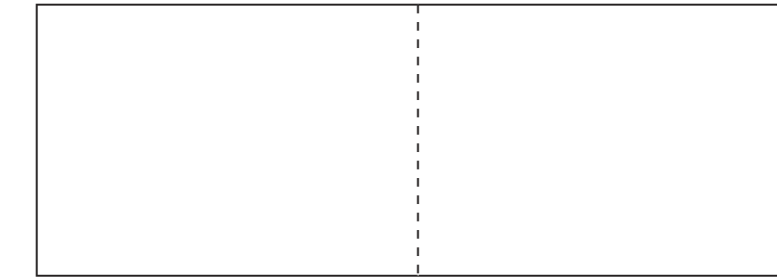

diagram 1

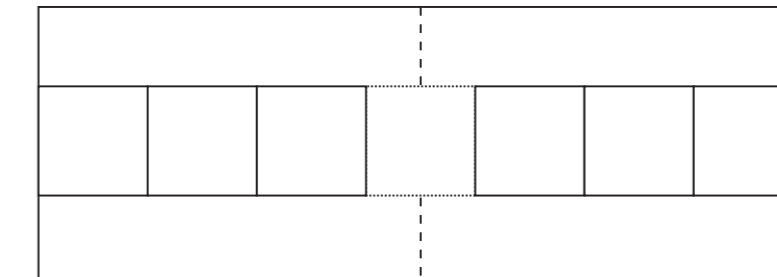

diagram 2

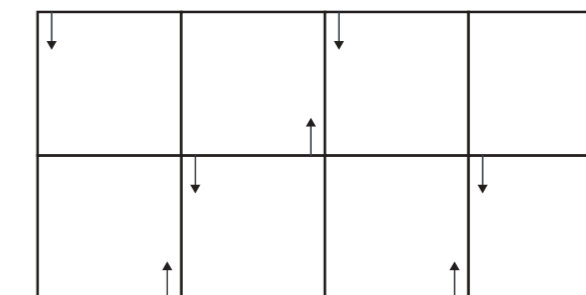

diagram 3

RANDOM TORN INSTALLATION

1. STRAIGHT EDGES

Begin by pasting 6-8 **Straight Edged** pieces with Tektura's Tekfix/Tekfix 65 adhesive.

Apply a generous amount of adhesive to each piece paying particular attention to the edges.

Allow adhesive to soak in for 3-5 minutes.

Randomly apply pieces to the edges of walls, around skirtings and door, smoothing the Decoupage from the centre outwards to achieve an even finish and trim as necessary.

Continue to apply until all straight edges have been utilized or this part of the installation has been completed.

In the event of further straight edged pieces being required, you may utilize the random torn pieces by cutting to size. Additionally, any remaining straight edge pieces may also be adapted, as required (*see Tearing to Shape section*).

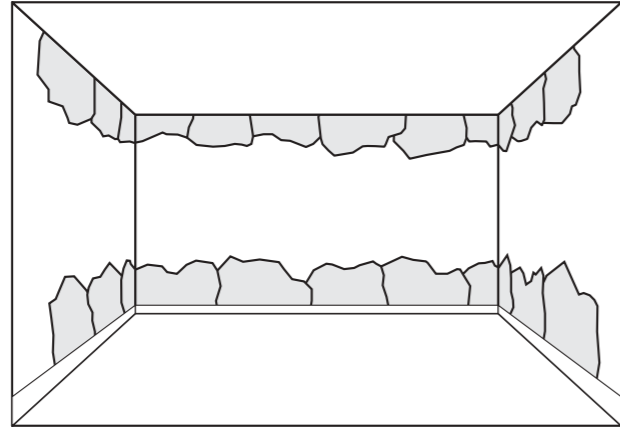

2. FILLING IN SPACES

Once all straight edged pieces have been applied, paste 6-8 remaining pieces at a time with Tektura's Tekfix/Tekfix 65 adhesive.

Allow adhesive to soak in for 3-5 minutes.

Fill in spaces and smooth each piece from the centre outwards to achieve an even finish and trim if necessary.

Inspect at regular intervals, and contact Tektura on 020 7536 3300 if you have any queries

For best results, see 'Tips for using Random Torn Pieces'. Larger pieces should be applied first, leaving the smaller spaces until last.

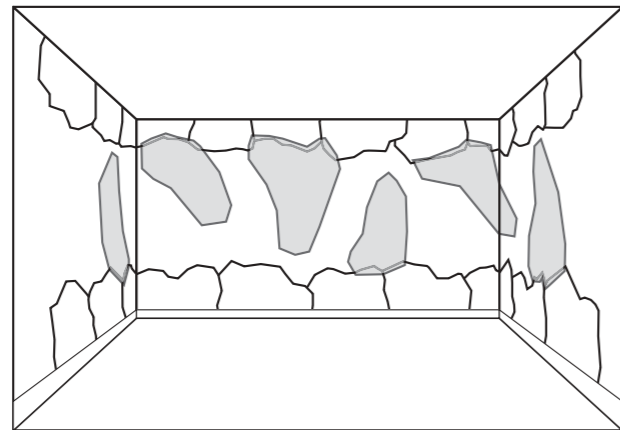

RANDOM TORN INSTALLATION

3. TEARING TO SHAPE

You may now be left with a number of undecorated areas in odd shapes and sizes.

Select appropriate pieces of Decoupage to fill in the remaining areas.

While dry, and before pasting, Decoupage maybe torn to the perfect size and shape in order to complete the installation. **NB. ensure you allow for a 2mm overlap when tearing these pieces.**

Once torn to size, apply a generous amount of adhesive to each piece paying particular attention to the edges.

Allow adhesive to soak in for 3-5 minutes.

Smooth each piece from the centre outwards to achieve an even finish and trim as necessary.

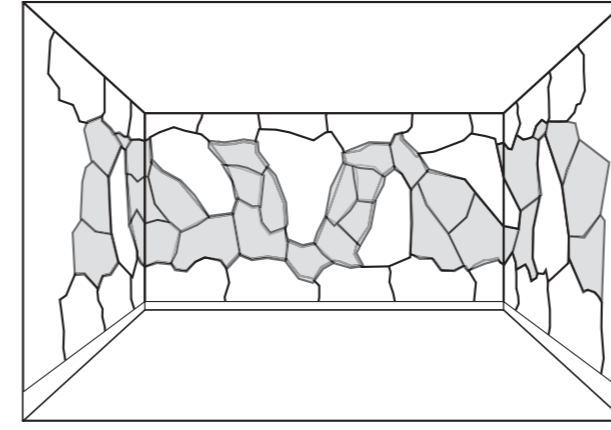

TIPS FOR USING RANDOM TORN PIECES

Pre-torn pieces are supplied in shapes designed to give the best possible results. When installing, these pieces should be kept as large as possible, and the overall effect on the wall should be of 'large boulders'. The overlapping joints should be kept as 'thin' as possible. Excessive overlapping can be unsightly and you may find you run out of material!

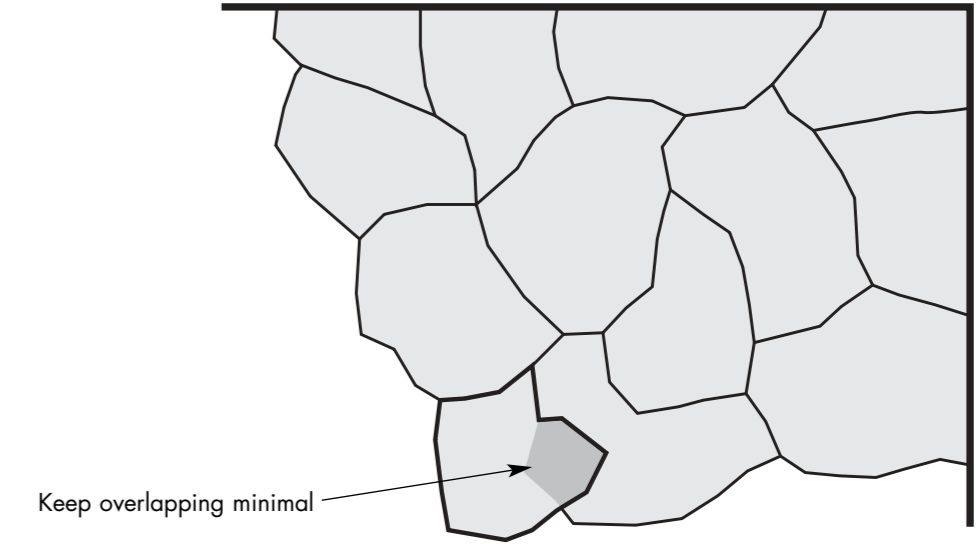

Keep overlapping minimal

Wherever possible, position the pieces so that the edges flow from one piece to the next, creating an effect of 'continuity'. This does take a bit more time and planning but creates the best overall effect

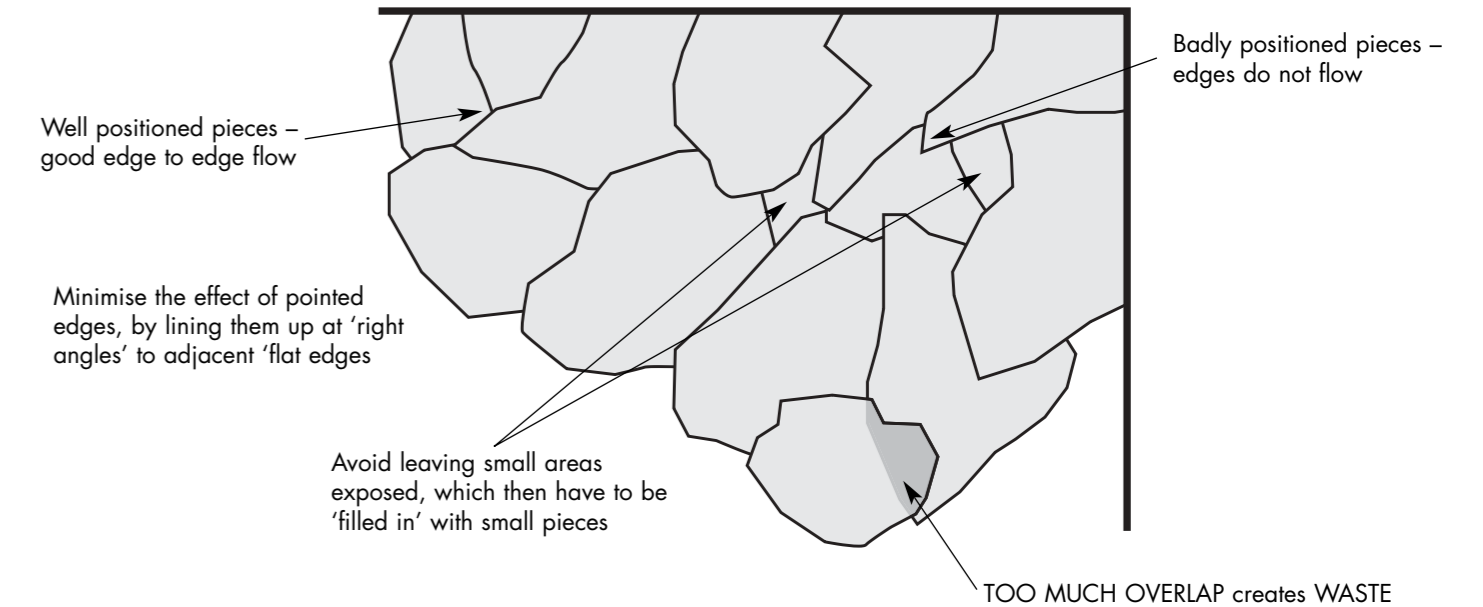

Well positioned pieces – good edge to edge flow

Minimise the effect of pointed edges, by lining them up at 'right angles' to adjacent 'flat edges'

Avoid leaving small areas exposed, which then have to be 'filled in' with small pieces

TOO MUCH OVERLAP creates WASTE

Badly positioned pieces – edges do not flow

In this picture, few pieces 'flow' from one edge to the next. The effect of large individual 'boulders' is not achieved.